

Townhouse A1	Im Brugrain 4c, 4147 Aesch	Objekt-Nr.	16572.05.0301
Objekt	3.5-Zimmer-Wohnung	Fläche	ca. 76.5 m ²
Etage	3. Obergeschoss	Keller	ca. 7.7 m ²

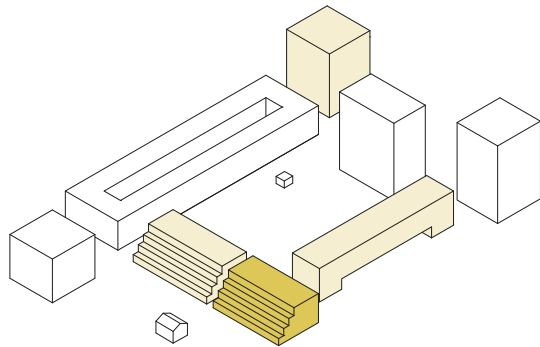

Situation

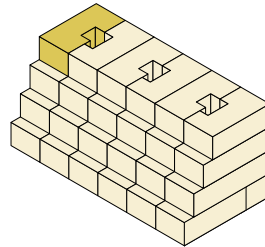

Schnitt

Grundriss

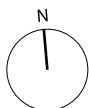

Massstab 1:100